

Phase-locking of Flux-Flow Oscillator by Harmonic Mixer based on SIS junction

Konstantin V. Kalashnikov^{**†}, Andrey V. Khudchenko^{**†}, Pavel N. Dmitriev, Valery P. Koshelets^{**†} and Andrey M. Baryshev[†].

^{*}The Kotel'nikov Institute of Radio Engineering and Electronics, Russian Academy of Science, 11/7 Mokhovaya St., 125009, Moscow, Russia
Email: Kalashnikov@hitech.cplire.ru

[†]SRON Netherlands Institute for Space Research, P.O. Box 800, 9700 AV Groningen, the Netherlands
Email : A.M.Baryshev@sron.nl

Abstract - A new approach to phase-locking of a Flux Flow Oscillator (FFO) [1] in a superconducting integrated receiver [2, 3] has been proposed and experimentally verified. According to this novel concept, a superconductor-insulator-superconductor (SIS) junction is implemented both for down-conversion of the FFO frequency and for formation of the signal to phase-lock the FFO to the external reference by applying the Harmonic Mixer (HM) output directly to the FFO control line. In other words, we introduce a new element of superconductive electronics, which is based on the SIS junction and works as a cryogenic harmonic phase detector (CHPD).

To realize efficient phase-locking of the FFO the HM output signal should be maximized. Value of this signal depends in a complicated way on the HM bias voltage, frequencies and powers of the local oscillator (LO) and the RF signals. We have studied the HM theoretically and calculated 3D dependences of the HM output signal power versus the bias voltage and the LO power. Results of the calculations have been compared with experimental measurements. Good qualitative and quantitative correspondence has been achieved.

For demonstration of the FFO phase-locking by the CHPD we have fabricated specially designed samples: all feedback loop elements are integrated on the same chip together with the FFO and the CHPD. The FFO frequency should be equal to a harmonic of the LO signal applied to the CHPD. Such a PLL system is expected to be extra wideband due to considerable reduction of the loop length. This concept is very promising for building of the multi-pixel SIR array.

I. INTRODUCTION: IDEA OF CRYOGENIC HARMONIC PHASE DETECTOR

A Phase Locking Loop system (PLL) based on Cryogenic Harmonic Phase Detector (CHPD) described in this report is a new way of phase stabilization of a superconducting flux flow oscillator (FFO) [1], which operates as a heterodyne source in a Superconducting Integrated Receiver (SIR) [2], [3].

The SIR circuit comprises on a single chip (size of 4 mm by 4 mm) a planar antenna integrated with an SIS (superconductor-insulator-superconductor) mixer, the FFO operating in the frequency range of 400 - 700 GHz and the second SIS harmonic mixer (HM) to phase-lock the FFO.

The block diagram of the SIR with conventional PLL system to stabilize FFO is presented in Fig. 1; this concept has been successfully used for the TELIS project [4].

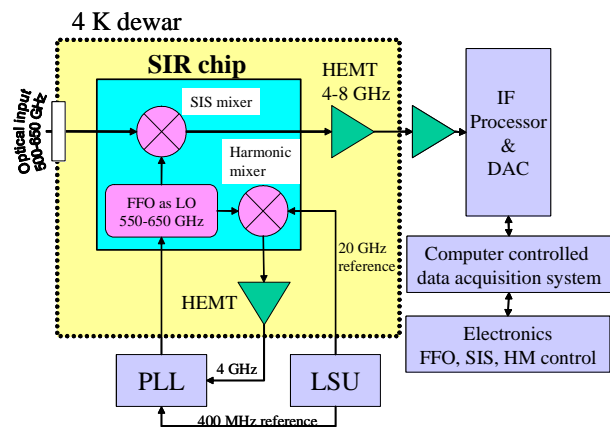

Fig. 1. Block diagram of SIR with RT PLL.

In the SIR with conventional PLL the FFO signal (frequency of about 600 GHz) is down-converted to 400MHz in the HM by mixing with n -th harmonics of the LO signal (frequency of about 20 GHz). The intermediate frequency (IF) signal is amplified and applied to a semiconductor phase detector placed outside the cryostat. The detector compares phase of this signal with one of the stable reference signal of frequency 400 MHz; the resulting error signal is applied to the FFO control line. This semiconductor PLL system has a bandwidth of about 15 MHz. Such a wideband PLL system is required because the FFO autonomous radiation spectrum has a Lorentz shape of width about few MHz. Only limited part of the FFO power can be synchronized by such a PLL system [5]. The semiconductor PLL system has to have long cables since the phase detector has to be outside the cryostat. The long cables lead to time delay, which limits the PLL synchronization bandwidth.

To overcome the problem of long cables and to synchronize the FFO power more efficiently a cryogenic PLL system has been developed [5] - [7]. Bandwidth of the cryogenic PLL system as large as 40 MHz has been realized. There are two SIS junctions in the loop of the cryogenic system. The first one works as the HM for down-convention of the FFO signal and second junction operates as a Cryogenic Phase Detector (CPD). The CPD compares the HM IF signal amplified by the HEMT-amplifier with reference oscillator signal of the same frequency (0.4 GHz [5], [6] or 4 GHz [7]). The resulting phase error signal changes the FFO control line current and adjusts the FFO frequency.

The novel concept of the FFO phase stabilization described in this report is based on employment of a single SIS junction as the HM and the phase detector simultaneously. This cryogenic harmonic phase detector (CHPD) substitutes the HM, the HEMT-amplifier and the CPD in the cryogenic PLL described above. The CHPD and all loop elements can be placed on the same chip with the FFO, which leads to loop delay reduction. Such PLL system will be ultra wideband that is important for the FFO phase-locking. A block diagram of the new PLL system is shown in Fig. 2. The signals from the FFO and the LO1 are applied to the CHPD. The frequency of harmonic of the LO1 signal is equal to the FFO frequency (~600 GHz). The CHPD generates output signal proportional to the phase difference between the FFO and the appropriate harmonic of the LO1. This error signal is applied directly to the FFO control line through a low pass filter.

For demonstration of the CHPD operation we used additional SIS Mixer. This mixer operates as a HM (see Fig. 2). It is utilized for observation of the FFO radiation line spectrum and monitoring of the phase locking effect. The LO2 frequency is chosen to obtain the intermediate frequency of this mixer of about 6 GHz.

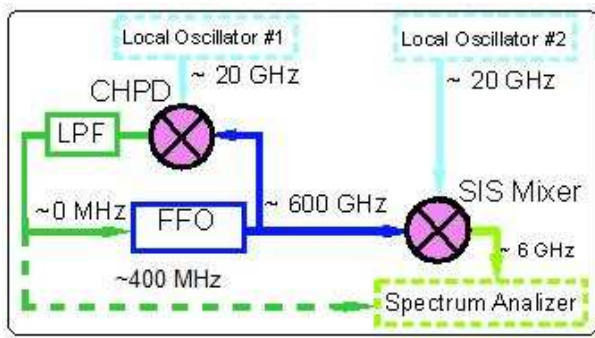

Fig. 2. Block diagram of the system for the FFO synchronization by the CHPD

II. ON THEORY OF HARMONIC MIXER

It is crucial to achieve a high-power HM output signal to demonstrate effective FFO synchronization. The experimental data shows that power of the IF signal depends in a complicated way on the HM bias voltage, frequencies

and powers of local oscillator LO and FFO signals. We have studied the HM theoretically and calculated the 3D dependences of its output signal power versus the bias voltage of SIS-junction and the LO power.

The detailed theoretical description of the SIS junction under action of microwave frequency signals is given in [8] – [10]. In [8] a simplifying assumption about the small amplitude of the input signal and shunting of the highest harmonics of the LO by junction capacitance was used. Papers [9], [10] involved the method of the SIS-junction description in general case, when the powers of input signals may be of any value. Nowadays the theory [9], [10] is the most complete; it takes into account existence of the harmonics generated by SIS-junction and influence of the external elec. The calculations of some characteristics HM on SIS based on this theory are given in [10].

We present the simpler model, which gives us the opportunity to reduce the time of HM characteristics calculation and still obtain good qualitative and quantitative agreement with the experimental data. Let us consider the model of the weakly-interacting quasi-particles under the influence of the periodic electric field without taking into account spin effects as in [11].

Wave function of a quasi-particle with energy E without applying altering electric field is $\Psi = f(x, y, z) \exp(-iEt / \hbar)$, where $f(x, y, z)$ – certain function of coordinates, i – imaginary unit, t – time, \hbar – Planck's constant. This wave function is the eigen function of a non-excited system Hamiltonian H_0 . The voltage across the junction is $V_{\omega_1} \cos(\omega_1 t) + V_{\omega_2} \cos(\omega_2 t)$ then two periodic signals of frequencies ω_1 , ω_2 and amplitudes V_{ω_1} , V_{ω_2} are applied to junction electrodes. The hamiltonian of quasi-particles system is then:

$H = H_0 + eV_{\omega_1} \cos(\omega_1 t) + eV_{\omega_2} \cos(\omega_2 t)$, where H_0 – non-excited system Hamiltonian, H – Hamiltonian of system influenced by two harmonic signals, e – charge of electron. The new wave function is

$$\Psi = f(x, y, z) \exp(-iEt / \hbar) \left(\sum_n B_n \exp(-in\omega_1 t) \right) \left(\sum_m C_m \exp(-im\omega_2 t) \right)$$

where B_n and C_m – unknown functions.

Applying this wave function to Schrödinger's equation $i\hbar \frac{\partial \Psi}{\partial t} = \hat{H} \Psi$, we obtain equations for B_n and C_m .

Solution of this Schrödinger's equation is:

$$\Psi = f(x) \exp(-iEt / \hbar) \left(\sum_n \sum_m J_n \left(\frac{eV_{\omega_1}}{\hbar\omega_1} \right) J_m \left(\frac{eV_{\omega_2}}{\hbar\omega_2} \right) \exp[-i(n\omega_1 + m\omega_2)t] \right),$$

where $J_n(\alpha)$ Bessel function n -th order

We can see that quasi-particles energy levels are split into levels described by wave functions Ψ_{nm} with energies $E + n\hbar\omega_1 + m\hbar\omega_2$; $n, m = 0, \pm 1, \pm 2, \dots$. Probability of

occupation of such levels is proportional to $J_n\left(\frac{eV\omega_1}{\hbar\omega_1}\right)J_m\left(\frac{eV\omega_2}{\hbar\omega_2}\right)$.

Quasi-particle tunnel current is provided by quasi-particles transport between SIS-junction electrodes. This current is described as complex function of current response $j(V)$, here V is a DC voltage applied to junction. The function $j(V)$ is calculated in [12]: $j(V) = iI_{dc}(V) + I_{KK}(V)$. Here $I_{dc}(V)$ is unpumped IVC of the SIS, and the $I_{KK}(V)$ relates to the $I_{dc}(V)$ as Kramers - Kronig transform.

It should be noted that the function $j(V)$ used in the calculations was measured experimentally. So the IVC of the HM contains information about the gap voltage and the current step.

The quasi-particle increases its energy by $\hbar\omega$ when the radiation quant is absorbed. This is the case identical with the applying voltage $\hbar\omega/e$ to junction. Therefore, the tunnel current is defined by function $j(V + \hbar\omega/e)$. As far as the quasi-particle is able to absorb several photons of the energy $\hbar\omega_1$ and $\hbar\omega_2$, in order to find the total tunnel current we should sum the current response functions $j_{nm} = j\left(V + \frac{n\hbar\omega_1}{e} + \frac{m\hbar\omega_2}{e}\right)$ subject to the probability of the quasi-particle tunneling. The quasi-particle transmission probability of state Ψ_{nm} to state Ψ_{lk} is defined by the matrix element $\langle \Psi_{lk} | \Psi_{nm} \rangle$, where

$$|\Psi_{nm}\rangle = f(x)\exp(-iEt/\hbar)\left[J_n\left(\frac{eV\omega_1}{\hbar\omega_1}\right)J_m\left(\frac{eV\omega_2}{\hbar\omega_2}\right)\exp[-i(n\omega_1 + m\omega_2)t]\right],$$

$$\langle \Psi_{lk}| = g(x)\exp(-iEt/\hbar)\left[J_l\left(\frac{eV\omega_1}{\hbar\omega_1}\right)J_k\left(\frac{eV\omega_2}{\hbar\omega_2}\right)\exp[i(l\omega_1 + k\omega_2)t]\right].$$

The changing summation variable leads to:

$$I(V, t) = \text{Im} \sum_{n,m,l,k} J_n(\alpha_1)J_{n+l}(\alpha_1)J_m(\alpha_2)J_{m+k}(\alpha_2) * \exp[-i(l\omega_1 + k\omega_2)t] j\left(V + \frac{n\hbar\omega_1}{e} + \frac{m\hbar\omega_2}{e}\right),$$

$$\text{where } \alpha_i = \frac{eV\omega_i}{\hbar\omega_i}.$$

It should be noted that we can overwrite the current function in the form:

$$I(V, t) = a_0 + \sum_{l=1}^{\infty} \sum_{k=1}^{\infty} (2a_{lk} \cos((l\omega_1 + k\omega_2)t) + 2b_{lk} \sin((l\omega_1 + k\omega_2)t)).$$

This formula shows that the signals of the frequencies described as $l\omega_1 + k\omega_2$ (l and k are integers) are generated on the SIS junction. For the practical application of the

harmonic mixer the first signal frequency is close to the frequency of second signal harmonic k , i.e. $\omega_1 - k\omega_2 \ll \omega_2$. Let us put that frequency of RF signal is $\omega_1 \equiv 2\pi f_{RF}$, and for LO signal is $\omega_2 \equiv 2\pi f_{LO}$. Then current amplitude of IF $f_{IF} = f_{RF} - nf_{LO}$ is given by

$$I_{IF} = \sqrt{a_{1k}^2 + b_{1k}^2},$$

$$a_{1k}(V) = \sum_{n,m} J_n(\alpha_1)J_m(\alpha_2) [J_{n+1}(\alpha_1)J_{m-k}(\alpha_2) + J_{n-1}(\alpha_1)J_{m+k}(\alpha_2)] * I_{dc}\left(V + \frac{n\hbar\omega_1}{e} + \frac{m\hbar\omega_2}{e}\right),$$

$$b_{1k}(V) = \sum_{n,m} J_n(\alpha_1)J_m(\alpha_2) [J_{n+1}(\alpha_1)J_{m-k}(\alpha_2) - J_{n-1}(\alpha_1)J_{m+k}(\alpha_2)] * I_{kk}\left(V + \frac{n\hbar\omega_1}{e} + \frac{m\hbar\omega_2}{e}\right).$$

The dependence of the IF signal's power versus the input signals' parameters and the bias voltage across the junction has been calculated by the presented formula. The result of such calculations is presented in Fig. 3.

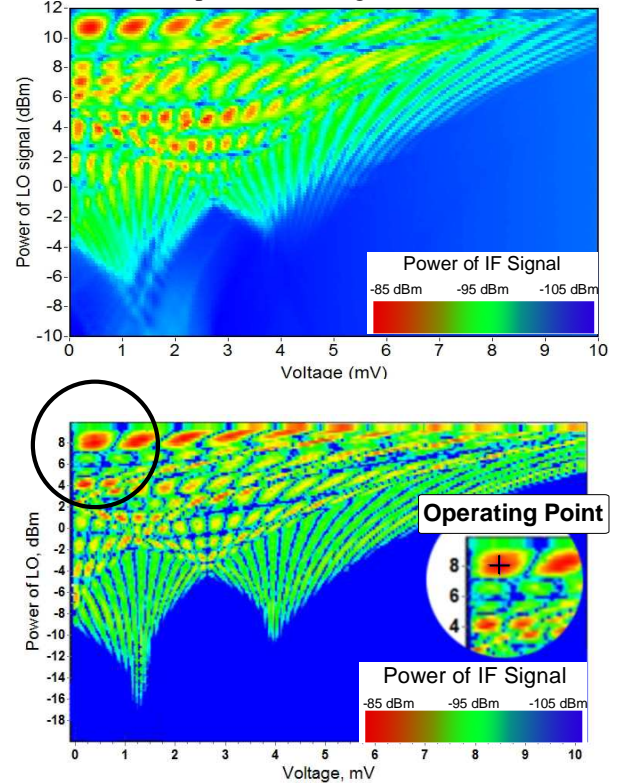

Fig. 3. Experimental (up) and theoretical (down) dependence of IF signal's power versus LO signal's power and bias voltage across the HM. The operating point with the maximum power of IF signal (-85 dBm) is shown on the theoretical dependence. The FFO frequency is 636 GHz, LO frequency - 18 GHz (the 35th harmonic of LO is used) as result frequency of IF signal is equal 6 GHz.

The experimental studying of such dependences was made. The dependence IF power versus LO power and bias

voltage was acquired. The frequency of the RF signal was 636 GHz, the LO frequency – 18 GHz. The critical current of the SIS junction was suppressed by the magnetic field. Good qualitative and quantitative correspondence has been achieved (Fig. 3). We used in experiment the Nb-AlO_x-Nb SIS junction with area of 1 μ² and gap current 90 μA. The maximal output signal power for described frequencies was obtained of about -90 dBm. Our calculations show that 5 dB larger value can be achieved at more careful adjustment.

III. EXPERIMENTAL RESULTS

A test circuit presented by the diagram in Fig. 2 has been experimentally realized. The feedback loop between the HM and the FFO was implemented in two ways: by lumped elements on a contact plate and by the microstrip lines directly on the chip.

In our experiment the FFO signal is split into two channels to pump both mixers. Each part of the signal is down-converted so that output signals frequencies are 400 MHz for the CHPD and of about 6 GHz for the SIS (Fig. 2). The IF signals are amplified and transferred to spectrum analyzers. The IF signal of CHPD is maximized by finding the optimal point (see Fig. 3). After the optimum is found, we change the frequency of the LO1 so that the IF of the CHPD becomes “0” instead of 400 MHz (the certain n-th harmonic of LO1 becomes equal to the FFO frequency). At the same time, the IF of the HM №2 is also changed but the FFO radiation line is still presented on spectrum analyzer screen and synchronization effect is observed.

The result of the FFO synchronization by the CHPD is shown in Fig. 4. This spectrum demonstrates the validity of the concept. The bandwidth of such a PLL system is expected to be about 100 MHz providing optimal gain in the loop. For the data presented in Fig. 4 (red curve) free running FFO linewidth is 6 MHz and such a system should phase-lock more than 90% of emitted power. Because the HM output signal is limited, the open loop gain is not large enough to demonstrate optimal synchronization. As a result, only 55% of the FFO emitted power is locked (see Fig. 4, blue curve).

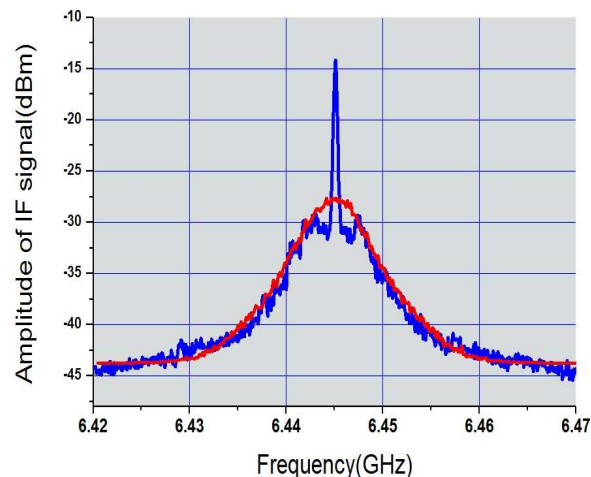

Fig. 4. Down-converting spectrum of FFO: red curve – free running line, LW = 6 MHz; blue curve – FFO is phase locked by the CHPD.

IV. SUMMARY

We propose a novel application of the SIS junction – the Cryogenic Harmonic Phase Detector (CHPD). The theoretical and experimental studies of the HM have been performed. Comparison of the theoretical and experimental data demonstrates a good qualitative and quantitative agreement. The concept of the CHPD is experimentally realized and the FFO phase locking has been obtained. The part of the phase-locked FFO power is not ultimate because output signal of HM was not large enough. This problem would be overcome by utilizing the HM with larger area. The application of a low-frequency superconductive on-chip amplifier in the feedback loop looks also very promising.

ACKNOWLEDGMENT

The authors thank Meno van den Bemt for the warm support and Michael Torgashin for fruitful and stimulating discussions.

The work was supported by the RFBR projects 09-02-00246, 09-02-12172 and Grant for Leading Scientific School 5423.2010.2.

REFERENCES

- [1] T. Nagatsuma, K. Enpuku, F. Irie, and K. Yoshida 1983 *J. Appl. Phys* **54** 3302, see also Pt. II: 1984 *J. Appl. Phys.* **56** 3284; Pt. III, 1985 *J. Appl. Phys* **58** 441, Pt. IV, 1988 *J. Appl. Phys* **63** 1130
- [2] V. P. Koshelets and S. V. Shitov, “Integrated Superconducting Receivers,” *Superconductor Science and Technology*, vol. 13, pp. R53-R69 (2000).
- [3] V. P. Koshelets, A. B. Ermakov, L. V. Filippenko, A. V. Khudchenko, O. S. Kiselev, A. S. Sobolev, M. Yu. Torgashin, P. A. Yagoubov, R. W. M. Hoogeveen, and W. Wild, “Integrated Submillimeter Receiver for TELIS”, “*IEEE Trans. on Appl. Supercond.*”, vol. 17, pp 336-342 (2007).
- [4] Gert de Lange, Dick Boersma, Johannes Dercksen, et al, “Development and Characterization of the Superconducting Integrated Receiver Channel of the TELIS Atmospheric Sounder”, *Supercond. Sci. Technol.* vol. 23, No 4, 045016 (8pp), (2010). <http://iopscience.iop.org/0953-2048/23/4/045016>
- [5] A. V. Khudchenko, V. P. Koshelets, P. N. Dmitriev, A. B. Ermakov, P. A. Yagoubov, and O. M. Pylypenko, “Cryogenic Phase Detector for Superconducting Integrated Receiver”, “*IEEE Trans. on Appl. Supercond.*”, vol. 17, pp. 606-608, 2007.
- [6] A. V. Khudchenko, V. P. Koshelets, P. N. Dmitriev, A. B. Ermakov, O. M. Pylypenko, and P. A. Yagoubov, “Cryogenic Phase Locking Loop System for Flux-Flow Oscillator”, ISST-08, vol 2, pp. 511-515, 2009.
- [7] A. V. Khudchenko, V. P. Koshelets, P. N. Dmitriev, A. B. Ermakov, P. A. Yagoubov and O. M. Pylypenko, “Cryogenic Phase Locking Loop System for Superconducting Integrated Receiver”, *Superconductor Science and Technology*, vol. 22, No8, 2009.
- [8] Tucker J. R., Feldman M. J. // *Rev. Mod. Phys.* 1985. V.57. №4. P.1055
- [9] Withington S., Kittara P., Yassin G. // *J. Appl. Phys.*, 2003. V.93. №12. P. 9812
- [10] Kittara P., Withington S., Yassin G. // *J. Appl. Phys.* 2007. V.101. №2. P.024508.
- [11] Tien P.K, Gordon J.P. // *Phys. Rev.* 1963. V. 129. №2. P. 647.
- [12] Werthamer N. R. // *Phys. Rev.* 1966. V.147. № 1. P.255