

550-650 GHz spectrometer development for TELIS

P.A. Yagoubov, W.-J. Vreeling, H. van de Stadt, R.W.M. Hoogeveen, O.V. Koryukin,
V. P. Koshelets, O.M. Pylypenko, A. Murk

Abstract—In this paper we present design and first experimental results of the 550 - 650 GHz channel for the Terahertz Limb Sounder (TELIS), a three-channel balloon-borne heterodyne spectrometer for atmospheric research. This frequency channel is based on a phase-locked Superconducting Integrated Receiver (SIR). SIR is an on-chip combination of a low-noise SIS mixer with quasioptical antenna, a superconducting Flux Flow Oscillator (FFO) acting as Local Oscillator (LO) and SIS harmonic mixer (HM) for FFO phase locking. The microcircuit is designed as a quasioptical mixer. Amplification of the mixer IF signal and first stage PLL circuitry is done by InP based low noise HEMT amplifiers. Optical design analysis and first experimental results, which include FTS and noise temperature measurements, are reported.

Index Terms — Josephson mixers, integrated receiver, superconducting devices

I. INTRODUCTION

TELIS (Terahertz Limb Sounder) is a cooperation between DLR (Institute for Remote Sensing Technology, Germany), RAL (Rutherford Appleton Laboratories, UK) and SRON (National Institute for Space Research, the Netherlands), to build a three-channel balloon-borne heterodyne spectrometer for atmospheric research. The three receivers utilize state-of-the-art superconducting heterodyne technology and will operate simultaneously at 500 GHz (channel developed by RAL), at 550-650 GHz (SRON in collaboration with IREE), and at 1.8 THz (DLR). TELIS is designed to be a compact, lightweight instrument capable of providing broad spectral coverage, high spectral resolution

Manuscript received May 2, 2005

The work was supported in parts by the RFBR projects 03-02-16748, INTAS project 01-0367, ISTC projects # 2445, 3174 and the President Grant for the Scientific School 1344.2003.2.

P.A. Yagoubov, W.-J. Vreeling, H. van de Stadt, and R.W.M. Hoogeveen, are with the National Institute for Space Research SRON, P.O. Box 800, 9700 AV Groningen, the Netherlands, (telephone: 31-50-3634074, e-mail: p.a.yagoubov@sron.rug.nl)

O.V. Koryukin and V.P. Koshelets are with the Institute of Radio Engineering and Electronics, Russian Academy of Science, Moscow, Russia; they are also partially with the National Institute for Space Research SRON, the Netherlands, (e-mail: valery@hitech.cplire.ru)

O.M. Pylypenko is with the State Research Center of Superconductive Electronics "Iceberg", Ukraine (e-mail: o_pylypenko@online.com.ua)

A. Murk is with the Institute of Applied Physics, University of Bern, Switzerland, (e-mail: axel.murk@mw.iap.unibe.ch)

and long flight duration (~24 hours duration in a flight campaign). The combination of high sensitivity and extensive flight duration will allow evaluation of the diurnal variation of key atmospheric constituents such as OH, HO₂, ClO, BrO together with longer lived constituents such as O₃, HCL and N₂O. The balloon platform on which TELIS will fly also contains a Fourier transform spectrometer MIPAS-B developed by the IMK (Institute of Meteorology and Climate research of the University of Karlsruhe, Germany). MIPAS-B will simultaneously measure within the range 680 to 2400 cm⁻¹. The combination of the TELIS and MIPAS instruments will provide an unprecedented wealth of scientific data and will also be used to validate other instruments and atmospheric chemistry models. The first flight is foreseen in 2006.

II. TELIS CONFIGURATION

The optical front-end of TELIS consists of a pointing telescope, calibration blackbody and relay optics, common for the three channels: 500 GHz, 550-650 GHz and 1.8 THz [1]. The telescope is a dual offset Cassegrain antenna. Primary, secondary and tertiary mirrors of the telescope are mounted on a common frame. The unit is rotated as a whole around the axis coinciding with the direction of the output beam to scan the beam through the required limb sequence on the sky. Primary parabola has an elliptical cross-section of 260x140 mm. 2:1 anamorphicity is introduced by the cylindrical tertiary mirror, which is flat in the vertical direction and spherical in horizontal. An anamorphic design was selected to improve telescope compactness, mass, and moment of inertia. A vertical (elevation) resolution at the tangent point is about 2 km at 500 GHz (FWHM), inversely proportional to the frequency. The limb scans range from upper troposphere (10 km) to stratosphere (30-40 km). Horizontal (azimuth) resolution is about a factor of 2 worse but not of prime importance for this mission as the atmospheric properties within the beam depend only on the altitude.

Calibration of the radiometric gain of the spectrometers is done with two blackbody reference sources at submillimeter wavelengths: the hot-load, which is a conical black-body at the ambient temperature, and the cold sky. The two references are measured in every antenna scan. The cold sky reference is measured with the telescope set at 40 degree upwards with respect to the limb position. For the hot load calibration, a

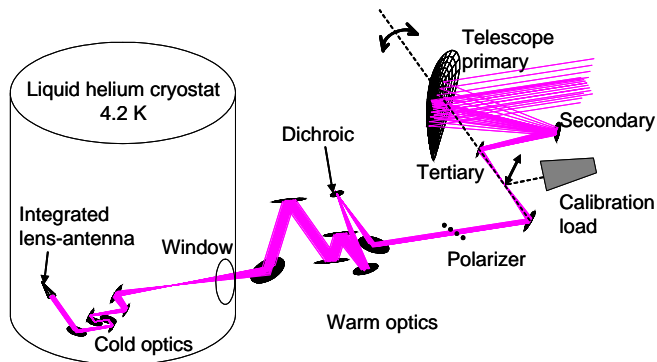

Fig. 1. Schematics of the 550-650 GHz channel optics. The telescope is rotated around the axis coinciding with the direction of the output beam. Wire grid polarizer and dichroic plate are used to separate this receiver from the two other frequency channels (not shown). The cold optics and mixer element are located inside the cryostat at the ambient temperature 4.2 K.

switching mirror is inserted between the telescope and the warm optics for the TELIS receivers to view the reference.

Frequency separation between the channels is performed quasioptically, allowing simultaneous observations by all receivers. First, one linear polarization of the incoming signal is selected by a wire grid and is reflected into the 500 GHz channel. The other linear polarization, which is transmitted by the grid, is then split between two other frequency channels by a dichroic filter. After the splitting, the three beams enter a custom designed liquid helium cooled cryostat. A number of off-set reflectors are used to interface the optics from the telescope to the cryogenic channels. Fig. 1 shows schematics of the optics directly related to the 550-650 GHz channel. The optical beams of the two other frequency channels after the splitting as well as their dedicated optical elements are not shown here.

Inside the cryostat the receivers have dedicated cold optics, mixing element and IF amplifiers. Three amplified output IF signals are fed to an IF processor which converts the IF to the input range of the digital autocorrelator of 2×2 GHz bandwidth. An on-board microcontroller controls the instrument and interfaces with the ground station.

III. SIR DESIGN

A key element of the 550-650 GHz channel is Superconducting Integrated Receiver (SIR) [2], which comprises in one $4 \times 4 \times 0.5$ mm³ chip a low-noise SIS mixer with quasioptical antenna, superconducting Flux Flow Oscillator (FFO) acting as Local Oscillator (LO) and SIS Harmonic Mixer (HM) for FFO phase locking, Fig. 2. The FFO is a long Josephson tunnel junction in which an applied dc magnetic field and a bias current drive a unidirectional flow of fluxons, each containing one magnetic flux quantum. The velocity and density of the fluxons and thus the power and frequency of the emitted mm-wave signal may be adjusted independently by joint action of bias current and magnetic field. The SIR microcircuits are fabricated on a Si substrate using high quality Nb-AlO_x-Nb tri-layer. The technological procedure does not require any additional equipment

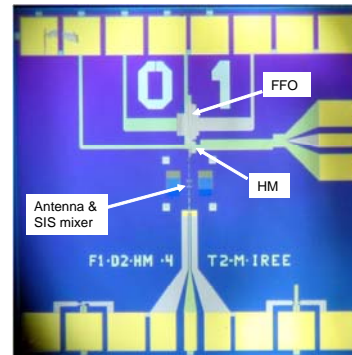

Fig. 2. Photo of the SIR chip. Antenna coupled SIS mixer, FFO and HM for FFO phase locking are located on a 4×4 mm² chip. FFO, SIS, and HM are connected with microstrip transmission lines, which contain a number of RF-coupling and dc-blocking elements. The SIS mixer and FFO are provided with local magnetic fields via integrated control lines.

compared to conventional SIS junction technology. The receiver chip is placed on the flat back surface of the Si lens, forming an integrated lens-antenna. One of the constraints implied by SIR is a requirement to place the receiver chip inside cylindrical magnetic shield, as FFO is very sensitive for the external interferences. The magnetic shield consists of two coaxial cans. The external layer is made from cryo-perm and the internal one is copper covered with 100 μ m of superconducting lead. The SIR chip is positioned far enough from the opening of the shielding cans, which is the only aperture for entering the signal beam and all electrical connections. The magnetic shield is 90 mm long and has an inner clear aperture of 25 mm. Thus the integrated lens-antenna configuration should be compatible with large f-number optics. This is realized by using an elliptical lens and locating the feed antenna at the more distant focus of the ellipse. The lens diameter of 10 mm is selected by optimizing for the minimum beam size at 100 mm from the integrated lens-antenna at 550-650 GHz, so that the shielding cylinder does not truncate the beam. To minimize the reflection loss at the lens-air interface, the curved surface of the lens is coated with a 74 micron thick Stycast antireflection coating, optimized for the center frequency 600 GHz.

IV. FFO PHASE LOCKING

SIR shall detect atmospheric lines with a spectral resolution of the order 5 MHz. To achieve this resolution, FFO is locked to an external reference oscillator using Phase Lock Loop (PLL) system. Schematically the FFO stabilization circuit and characteristic frequencies of its subsystems are shown in Fig. 3. The required references are provided by the Local oscillator Source Unit (LSU), all phase locked to the internal 10 MHz Master Oscillator.

FFO is used as a 550-650 GHz LO for the SIS mixer. A small fraction of the FFO is also directed towards the integrated on the same chip HM. The latter mixes the FFO with the n-th harmonic of the 19-21 GHz reference. The mixing product at 4 GHz is amplified by a cryogenic HEMT amplifier. In the PLL the mixing product is downconverted to

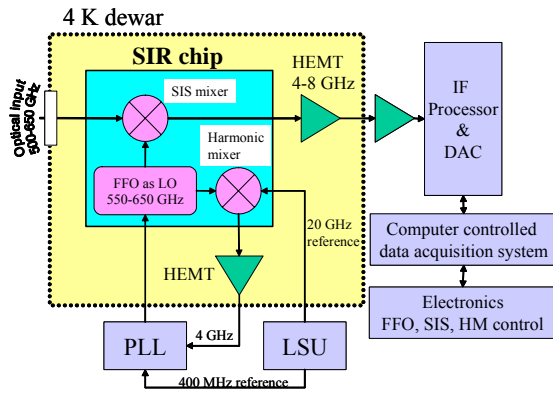

Fig. 3. Schematics of the FFO stabilization circuit. FFO frequency is mixed in HM with the 19-21 GHz reference. The mixing product is amplified, downconverted and compared with the 400 MHz reference in the PLL. The phase difference signal generated by PLL is used to feedback the FFO control line.

400 MHz, and its frequency and phase are compared with the reference 400 MHz. Finally, the phase difference signal generated by the PLL is used as a feedback to the FFO control line current to compensate for the phase error. To obtain wideband operation of the PLL (15 MHz full width), it resides right outside the cryostat to minimize the total loop length. Dedicated software (IRTECON) controls SIR electronics and PLL settings, allowing automatic optimization and remote operation of the phase locked SIR.

V. SIR CHANNEL COLD OPTICS

The SIR cold channel optics consists of the integrated lens-antenna, Martin-Puplett polarizing interferometer used as a SSB (Single Side Band) filter and a number of curved and fold mirrors, all located in the liquid helium cryostat at the ambient temperature 4.2 K. The layout of the optics is shown in the Fig. 4. The interface of the SIR channel optics to the telescope & warm optics system is defined at the position of an image of the pupil which is located outside the cryostat window 160 mm in front of the warm parabolic mirror (L1). The interface accepts a “parallel” and frequency independent beam. The input beam waist has a radius of 11.0 mm for all frequencies. An off-axis parabolic mirror (L1) focuses the beam into an image of the sky located about 70 mm behind the cryostat window (L2). Between the cryostat window and the first cold mirror (L3), infrared radiation filter (not shown in the Fig. 4) and a grid for injecting the cold image load are located. The ellipse L3 serves as an optical relay. Just in front of the magnetic shielding cylinder is a combination of 2 curved mirrors (L4 and L5). With suitable focal lengths they image the system-pupil in the front surface of the integrated lens antenna. Thus we have frequency independent imaging. A de-magnified image of the sky is projected on the chip on the back surface of the elliptical lens (L6). All optical components have a minimum diameter of 4 beam radii (1/e field level), corresponding to an edge taper of -35 dB. Only the integrated lens is smaller than 4 beam radii. (L3), (L4) and (L5) mirrors are $\sqrt{2}$ larger in horizontal direction than in

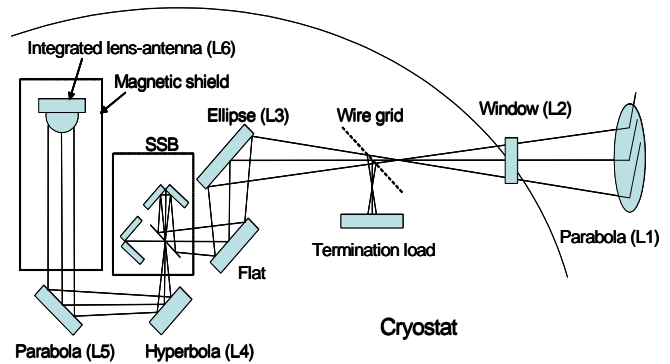

Fig. 4. Layout of the cold channel optics. Lines show the optical beam trajectories.

vertical direction, because of the 45 degrees angle of incidence.

VI. VERIFICATION OF THE OPTICAL DESIGN

The quasioptical performance of the reflective optics of the TELIS instrument has been calculated using the GRASP8 package [3] (from TICRA in Denmark). To simulate the 550-650 GHz cold (located at 4.2 K) channel we used configuration illustrated by Fig. 4. The center frequency is 625 GHz. As an input feed, the calculated by PILRAP (Program for Integrated Lens and Reflector Antenna Parameters [4]) integrated lens-antenna system field distribution is used. The SSB filter is replaced by a set of two plane mirrors to maintain the optical path length, as we could not find a way to model accurately roof top mirrors in GRASP.

Fig. 5 shows the far field beam profile simulated by GRASP. Solid lines are the power patterns in the vertical (perpendicular to the optics base plate) and horizontal planes.

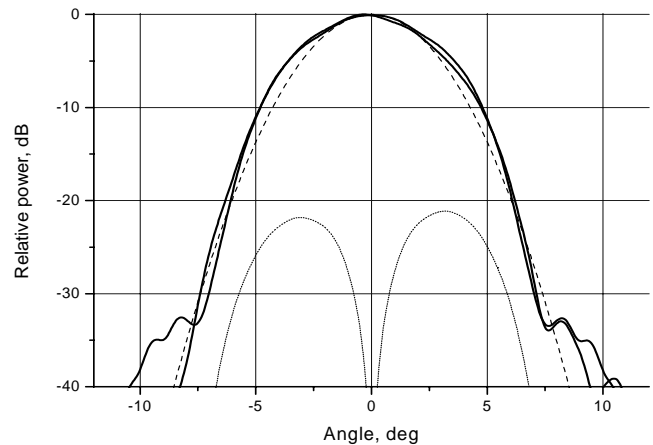

Fig. 5. Calculated far field beam pattern of the 550-650 GHz cold channel. Frequency is 625 GHz. Solid lines show beam pattern in two orthogonal planes. Dotted line is a cross-polarization component. An ideal Gaussian profile is indicated by the dashed line.

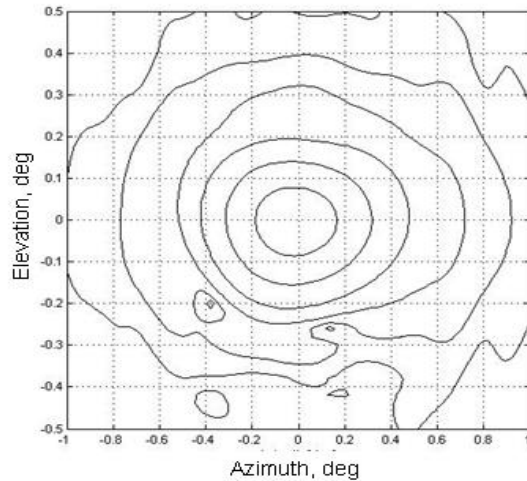

Fig. 6. Calculated far field 2-D beam profile of the 550-650 GHz instrument, including the warm optics and telescope, at 625 GHz. Solid lines represent the -3 dB and the -10 dB to -50 dB contours.

One can see that in one plane (vertical) the beam is absolutely symmetric. A 13% asymmetry (expressed as a difference of integrated powers in positive and negative angles) in the horizontal plane is caused by non-axisymmetric optics in this plane. The dotted line indicates a cross-polarization component which appears at < -20 dB level. Just for a reference purpose, an ideal Gaussian beam profile is indicated by dashed line.

Complete optics of the 550-650 GHz receiver, including the cold channel, warm optics and the telescope (as drawn in Fig. 1), was also simulated by GRASP. Fig. 6 shows calculated 2-D far field pattern of the receiver at 625 GHz. The pattern exhibits an elliptical form (note different scale in azimuth and elevation) determined by the anamorphicity of the telescope. Strongly asymmetric pattern in the azimuth plane is mainly caused by the fast off-axis optics of the telescope. However, for the atmospheric limb scans, only the vertical (elevation) profile of the receiver beam is of interest for the retrieval, while the atmosphere is uniform in the horizontal plane within the field of view.

The 2-D results were used to calculate the 1-D vertical profile and Azimuthally Collapsed Antenna Pattern (ACAP) by summing over the co- and cross-polarization amplitudes at each elevation, Fig. 7. FWHM of the ACAP at 625 GHz is 0.17 deg, corresponding to a 1.65 km FWHM beam at the tangent point in 550 km distance. The ACAP is symmetric and has an almost Gaussian shape for amplitudes larger than -20 dB. An asymmetric sidelobe starts at the -25 dB level. This beam shape will be relevant for the retrieval of atmospheric data and has to be considered in the retrieval model. The calculated total spillover loss of the optics (not including the integrated lens-antenna) is $< 10\%$.

VII. ALIGNMENT AND TOLERANCE ANALYSIS

An optical configuration of the TELIS SIR channel consists of about 20 optical elements, located within three major sub-assemblies: telescope, warm optics and cold channel.

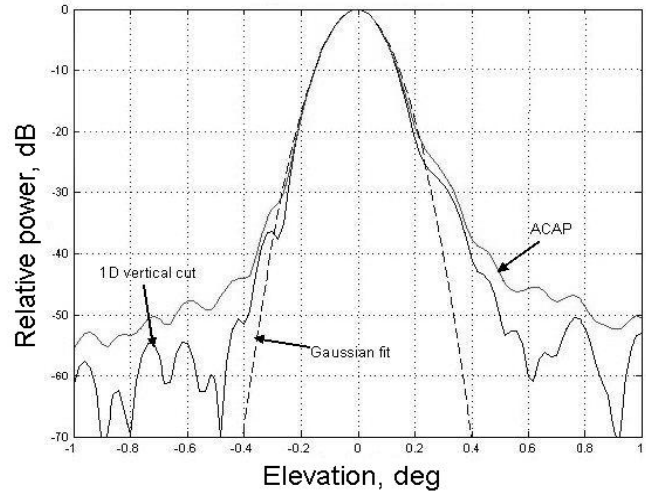

Fig. 7. Calculated far field 1-D vertical (elevation) cut and ACAP at 625 GHz.

Fabrication and positioning errors of each element and sub-assemblies as a whole cause deviation of the optical performance from the ideal design. Therefore, comprehensive study of mechanical tolerances and their impact on the system performance has been performed using commercial programs ZEMAX for Geometrical Optics analysis and GRASP for Physical Optics analysis. There are other factors as well which cause deterioration of the system performance during the maintenance. These are thermal effects, position non-reproducibility of the sub-assemblies or potential deformations caused by 5g acceleration during instrument landing. These all made it absolutely necessary to envisage visible light alignment and/or verification. For this reason, all reflective optical elements, including the telescope, are required to have an optical surface quality.

A. Geometrical optics analysis

As a first step, an inverse sensitivity analysis of mechanical tolerances was performed using ZEMAX. Both linear and angular misalignments of each optical element were considered. Shapes of reflecting surfaces were assumed to be ideal. In the inverse sensitivity mode ZEMAX computes the value of each tolerance that will result in the decrease in performance specified by Max Criteria. Only one optical element is perturbed at once, other elements remain unperturbed. For the Max Criteria we selected a maximum offset of $1/3$ beam radius ($1/e$ field level) at each mirror. This criterion keeps under control the aperture efficiency and spillover loss as the size of all optical elements is 4 beam radii. This analysis identifies optical elements most critical to the misalignments and their individual tolerances.

As a next step, statistical (Monte Carlo) analysis of the tolerances was performed. This method analyses the effect of all perturbations simultaneously. For each Monte Carlo cycle, all parameters which have specified tolerances are randomly set using the defined range of the parameter (found by the inverse sensitivity analysis) and a statistical model of the distribution of that parameter over the specified range. More

than 200 Monte Carlo cycles were run to get statistics on performance degradation.

As a last step, all tolerances, and especially those of most critical mirrors, have been tightened until the performance degradation is in 90% of the runs within the Max Criteria mentioned above. Similar analysis was performed for the groups of elements. This covers the cases of global misalignment of the cold channel and the telescope with respect to the warm optics. The geometrical optics tolerance analysis allowed us to draw the following conclusions:

- Typical angular tolerance within the cold channel is 0.06-0.08 deg. This can be translated to a linear tolerance of about 20 micrometers. All elements can be mounted on the common baseplate using dead-reckoning, if the above mentioned mechanical accuracy is maintained for all mirrors and the baseplate. Visible light alignment verification should be performed to check for fabrication errors.
- Within the warm optics, the typical angular tolerances are 0.1-0.2 deg, translated to about 30 micrometers requirements for the production.
- The telescope should be aligned with visible light.
- The tolerances on position and rotation of groups of elements can not be met. Therefore, two first (after the telescope) and last mirrors in the warm optics should have alignment possibility to (co)align the warm optics with the telescope and cold channel, respectively.

B. Physical Optics analysis

The physical optics simulations are time consuming and allow only a limited number of cases to be analyzed. We have selected the cases of global misalignments between the sub-assemblies.

The simulations of the telescope to warm optics misalignments showed that ± 1 mm lateral and ± 0.5 deg misalignments do not degrade substantially the quality of the beam, and keep it within the requirements. The FWHM of the ACAP changes are within 3%, spillover loss is not increased by more than 0.5%, the difference in sidelobes is only noticeable at < -25 dB level. A maximum pointing error of ± 0.04 deg will cause a beam shift of ± 0.4 km at the tangent point, close to the requirement on ± 0.5 km beams co-alignment on the sky of the three frequency channels of TELIS instrument.

A case of warm optics to cold channel misalignments is particularly interesting as the reproducibility of the cold channel mount in the cryostat is not yet known and could be poor because of thermal cycling. In this case, the effects of lateral misalignments of ± 1 mm and angular misalignments of ± 0.3 deg were investigated. Here, the results are in general very similar to the previous case. Note only that here the angular tolerances are almost a factor of two tighter. In conclusion, we have shown that the main requirements on the maximum performance degradation due to sub-assemblies misalignments could be met if the tolerances are within ± 1 mm and ± 0.5 deg for the telescope-warm optics interface

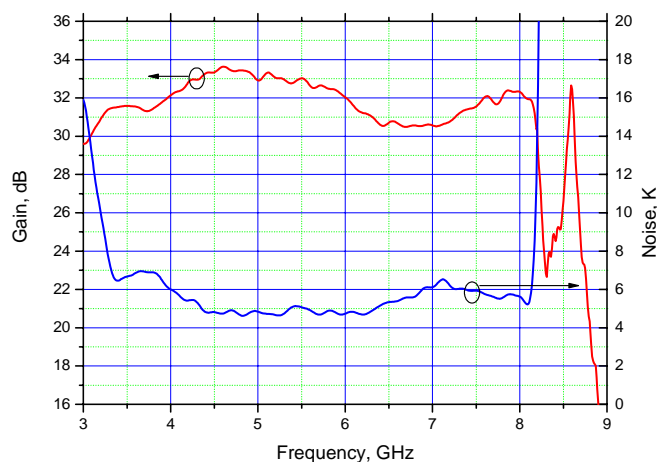

Fig. 8. Gain and noise temperature of the LNA based on InP transistors.

and ± 1 mm and ± 0.3 deg for the cold channel-warm optics interface.

VIII. IF CHAIN

Intermediate Frequency (IF) signal of the SIR is amplified by 4-8 GHz cryogenic HEMT Low Noise Amplifier (LNA). LNA has two stages and is based on InP transistors. The amplifier is integrated with Pamtech isolator. Gain and noise temperature of the amplifier were measured at 4.2 K ambient temperature, results are shown in Fig. 8. Noise performance was determined using Y-factor technique with a 50Ω load at the amplifier input. Temperature of the load was varied in a range from 6.5 to 15 K. An output was further amplified by a room temperature amplifier (total gain 67 dB, noise temperature < 150 K) and registered by a spectrum analyzer. Both gain and noise of the LNA were measured during one cooling cycle using a cryogenic switch to connect LNA to either external signal for gain measurements or internal heatable 50Ω load for noise measurements. Gain is corrected for the loss in the dewar cables; noise temperature is corrected only for the 0.2 dB cable loss. The total power dissipation of the LNA is 5 mW.

IX. EXPERIMENTAL RESULTS

The experimental results discussed here have been obtained with the SIR device (T3-031#6) of the most recent design [5]. Optimization of the FFO-SIS and FFO-HM matching circuits and implementation of submicron junctions for both mixers improved pumping of SIS and HM by FFO. As seen from the Fig. 9, both mixers have enough FFO power for the optimum operation in the frequency range 500-640 GHz. The data are normalized to the I_g (current just above the gap voltage) of each mixer. Dashed lines indicate the operation level of corresponding mixer, 0.25 is optimum for the SIS, while 0.05 is enough for the HM. The latter mixer needs less power due to highly non-linear regime of operation [6]. Note that the curves show the envelope (maximum) of a set of data taken at different magnetic fields applied to the FFO by control line. SIS mixer is based on twin submicron ($0.8 \mu\text{m}^2$) Nb-AlO_x-Nb

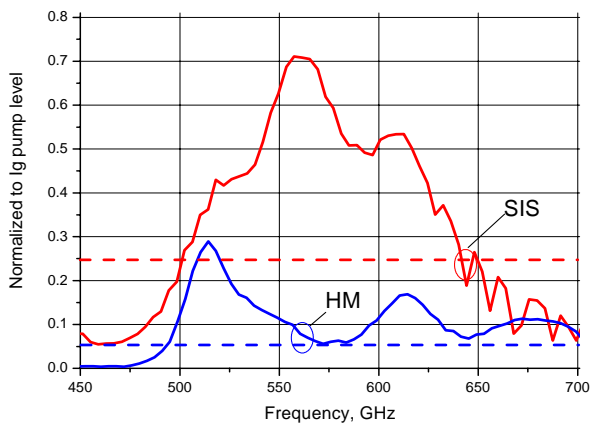

Fig. 9. Pumping of SIS and HM by FFO, normalized to their individual I_g . The dashed lines indicate optimum levels, 0.25 for the SIS, and 0.05 for the HM. Note that the curves show the envelope (maximum) of a set of data taken at different control line currents of the FFO.

tunnel junctions with $J_c > 7 \text{ kA/cm}^2$. SIR chip is mounted in a “flight” mixer block surrounded by magnetic shield. No other optical elements of the cold channel were installed yet for these very first measurements. All tests reported here were done in a liquid helium cooled cryostat at 4.2 K ambient temperature. Noise temperature measurements are done using Y-factor technique by chopping between hot (295 K) and cold (80 K) loads in the signal path of the receiver. IF response of the mixer is amplified by a “flight” IF chain configuration. It consists of a cryogenic InP based 4-8 GHz LNA amplifier followed by a RT amplifier. The signal is detected by fast power meter in 40 MHz bandwidth, selected by tunable YIG filter. We have also used “flight” configuration of the PLL system and could lock the FFO practically at any frequency in the 550-650 GHz range.

Fig. 10 and Fig. 11 show the FTS response of this device measured in direct detector mode and results of Noise Temperature (NT) measurements, which are not corrected for any loss. The minimum DSB NT of 250 K is measured at 520 GHz, slightly outside the designed frequency range. From these graphs one can see that NT data correspond well to that of FTS. Frequency dependence of the mixer response is in general determined by combination of few factors: design of the antenna-mixer and matching circuits, SIS junction area and its current density. It is obviously a challenge to optimize performance of three interdependent superconducting elements on one chip in such wide frequency range. Further experimental tests of different chip configurations and development of SIR microstrip coupling circuitry are needed.

ACKNOWLEDGMENT

The authors thank M. van der Vorst for supplying PILRAP, Microwave Electronics group of Swiss Federal Institute of Technology in Zurich (ETHZ) for supplying InP transistors. T. de Graauw and W. Wild are acknowledged for their support in this work, L. Filippenko for SIR microcircuit fabrication.

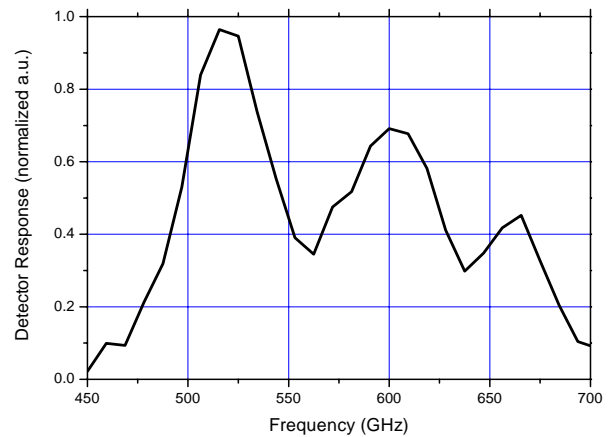

Fig. 10. FTS response of the SIR measured in direct detector mode.

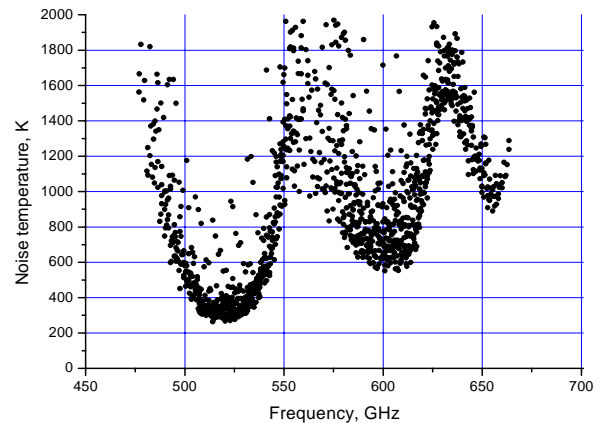

Fig. 11. Noise temperature of the SIR. At each frequency different values of magnetic field was applied to the FFO. Magnetic field controls power of the FFO and thus pumping level of the SIS, resulting in a set of data points.

REFERENCES

- [1] Hoogeveen, R.W.M., Yagoubov, P.A., Maurellis, A.N., Koshelets, V.P., Shitov, S.V., Mair, U., Krocka, M., Wagner, G., Birk, M., Hübers, H.-W., Richter, H., Semenov, A., Gol'tsman, G., Voronov, B., Ellison, B., Kerridge, B., Matheson, D., Alderman, B., Harman, M., Siddans, R., Reburn, J., eds. Strojnik, M., “New cryogenic heterodyne techniques applied in TELIS: the balloon borne THz and submm limb sounder for atmospheric research”, Proc. of SPIE, Infrared Spaceborne Remote Sensing XI, 5152, p. 347-355, 2004.
- [2] V. P. Koshelets *et al.*, “Towards a Phase-Locked Superconducting Integrated Receiver: Prospects and Limitations,” *Physica C*, vol. 367, pp. 249-255, 2002.
- [3] Knud Pontoppidan, editor. “*Technical Description of GRASP8*”. TICRA Engineering Consultants, Copenhagen, Denmark, 2003. ISBN 87-989218-0-0.
- [4] M. J. M. van der Vorst. Integrated Lens Antennas for Submillimeter-wave Applications. PhD thesis, Elect. Eng. Dept., Eindhoven Univ. Technol., Eindhoven, The Netherlands, 1999.
- [5] Valery. P. Koshelets, Pavel N. Dmitriev, Andrey B. Ermakov, Lyudmila V. Filippenko, Oleg V. Koryukin, Andrey V. Khudchenko, Mikhail Yu. Torgashin, Pavel A. Yagoubov, Ruud W.M Hoogeveen, and Wolfgang Wild, “Superconducting Submm Integrated Receiver with Phase-Locked Flux-Flow Oscillator for TELIS”, this Proceedings
- [6] V. P. Koshelets *et al.*, “Optimization of the Phase-Locked Flux-Flow Oscillator for the Submm Integrated Receiver”, *IEEE Trans. on Appl. Supercond.*, vol. 15, no. 2, June 2005.